



PERKA



BUILDING FRAMES

Assembly Guide

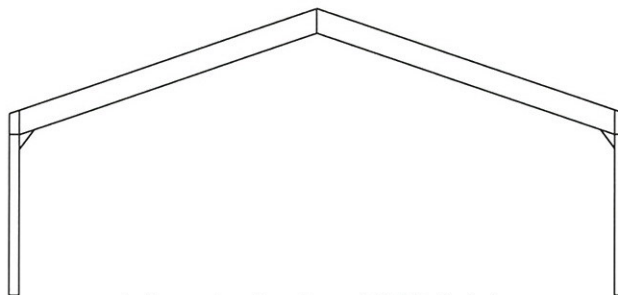

Model I-BEAM

INTRODUCTION

Perka Building Frames offers a wide variety of frame designs to suit many needs at virtually any size and any shape. All frames are made of steel and fully conceived through state of the art computer technology.

Each frame is computer designed:

- (a) To optimum strength, meeting building code requirements.
- (b) To maximum efficiency, meeting all cost factors in both materials and erection.
- (c) To maximum flexibility, meeting all possibilities of building uses, and optimizing the frame's versatility, reliability, and therefore, its investment.

This manual is provided to assist in the assembly/erection of the frames that you purchased; in no way is it intended to be the "only way" to do it. It is based on a survey of several contractors and is a direct reflection of popular industry procedures. Therefore, this manual is to be perceived as a guide only.

Based on your own experience and personal preference, you may deviate from this guide especially where personal design options or individual building requirements have been requested and do not make up part of a typical frame of your model type.

Furthermore, certain procedures may differ where location, weather conditions, or the skills of the personnel would render the methods of erection described herein unsafe or undesirable.

It is the responsibility of the erector, not the manufacturer, to determine a safe, convenient and proper method of erection having regard to all the particular circumstances at hand.

Should you have any difficulties with any part of your building, we urge you to contact your building consultant or supplier to minimize your time and cost factors.

Note that it is also recommended that you contact your insurance agent; this is an often overlooked necessity with a product of this kind.

So, best regards and good building.

FromTeam

Perka 2009

RECEIVING YOUR BUILDING

Most shipments of steel buildings are made to provide sufficient material to begin erection of the structure upon arrival at the job site. In multi-truck shipments, framing material is sent out first, sheeting and trim usually loaded and shipped last.

Notification of shipment is usually made at least 24 hours before delivery. All delivery commitments are approximate. While every effort is made to maintain schedule, **Perka Building Frames and or its assignees** cannot be held responsible for any damages caused by delays.

Great care should be exercised in scheduling erection crews and unloading equipment on a job site, usually not before the erector is certain of the arrival of material.

Helpful Hints

General:

Accessories, trim and sheeting bundles should be set aside and out of the way of traffic around the site. Purlins, Girts (if all steel building) should be distributed along both sides of the foundation. Structural framing material should be unloaded within the foundation, close to where it will be erected and with consideration to accessibility of erection equipment.

*** Make sure you have everything:**

From your bills of lading, check off everything as you unload it. Do not break cartons or bundles until required... (ie. to count sheets or to use) this will prevent excessive dirt and moisture from getting on your materials.

Use dunnage under all building materials:

Components left on the ground are subject to excessive moisture and dirt and can give the erector the unhappy task of cleaning or repainting after building is erected. The dunnage will also facilitate ground assembly of frames and provide space for lifting slings when erection begins.

Take great care in handling sheeting and trims:

Erection personnel must be made fully aware of the value of your sheeting and trims. Careless handling of these items could create major problems for the builder and much dissatisfaction on the part of the owner. Packages of sheeting and trims must be stored off the ground at a sufficient height to allow air circulation under the packages. This will avoid surface moisture and reduce condensation.

Releasing truck:

After satisfying yourself that you have accounted for all of your materials and making any necessary notations on the bills of lading, sign the driver's copy and release the truck.

BEFORE YOU BEGIN

With every order of Perka Building Frames, you will receive the following:

1. Confirmation of your order.
2. Anchor Bolt Layout.
3. Your model # & assembly guide/manual.
4. If requested, Engineer certified drawing of your frame. This page(s) will also show elevations and may have details of special features/options.
5. A bill of lading, listing in detail, all your building materials/components.
6. Warranty

It is imperative that as you receive these, you take the necessary time to review immediately and thoroughly.

Perka Building Frames has a reputation for extremely rapid delivery and the only way it can continue to meet this requirement and offer high quality workmanship right through the order is if all parties understand the value of time and follow through with the same sort of commitment... please note that we're not talking haste, we're talking **time-management**.

So, please look over each item attentively and if there is anything in question, contact your building consultant immediately.

Please note also that it is responsibility of owner/erector to ensure compliance with specifications and or installation criteria from other supplier(s) and manufacturer(s).

NOTES ON TOOLING

The following is a list of tools and equipment used by a "typical" crew who will erect the structural frames and apply the sheeting and trims. Equipment requirements will vary from job to job due to differences in building sizes, complexities, job site conditions and erection personnel.

Therefore, this list should be used as a guide and in no way puts a limitation on equipment for erection crews.

1. Wrenches, for 1/2", 5/8", 3/4", 7/8" or 1" bolts.
2. Set of ratchet drivers 20" or 24"; 3/4" - 1" drive and sockets.
3. Wrecking bar, 8# sledge hammer and heavy duty drift pins 5/8", 3/4", 7/8", 1" and 1 1/16".
4. Set of torches, gauges, hose, and tips.
5. Measuring tapes, 100' & 25'.
6. Some 5/8" or 3/4" pure manila type rope.
7. Some cable and turnbuckles for temporary anchoring.
8. Heavy duty belt slings, 3/4 wire cable chokers, spreader bars.
9. 30' extension ladders
10. Assortment of crescent wrenches.
11. Heavy duty, high speed screw guns or impact guns with depth setter, clutch, and magnetic socket heads.
12. Electric sheet metal nibblers.
13. Heavy duty electric drill and bits.
14. Hack saws and blades.
15. Welding machine.
16. Extension cords.
17. Heavy duty electrical cable.
18. Nylon string line.
19. Chalk line.
20. Vise grips.
21. Ramset or pin boy's.
22. Scaffolding or scissor lifts.
23. Levels, plumb bobs, drift pins.
24. Hard hats, gloves.
25. "Come along".

FOUNDATION NOTATION

It is generally recommended that foundations be designed and "formed" by competent local experts (i.e. foundation engineers or designers and their associated or recommended contractor).

This is so, because they are usually most familiar with the location's site and soil conditions. Having knowledge of and experience with the local code requirements, drainage, soil bearing capacity and available tools and materials in your neighborhood will assure that you start out with the right foundation, meeting all specific loads imposed upon it.

Perka Building Frames provides all orders with an Anchor Bolt Layout and on that sheet it will show all the necessary column reactions that your foundation contractor/designer must account for.

Since a poor foundation is the major cause of most erection problems, it is also important that a responsible person check the concrete form work and anchor bolts for location, alignment, and elevation prior to and during the concrete pouring. This will prevent the potential of some costly complications during erection of your frames.

Similarly, it is a good idea to check all anchor bolts one more time before the erection crew arrives... just in case! If you know before, you can save several hours of men and equipment from waiting while corrective measures are being taken.

HELPFUL HINTS ON READING YOUR ANCHOR BOLT LAYOUT

To locate your different frames/columns marked on your bill of ladings, refer to the anchor bolt layout and read it as a grid. One side being labeled alphabetically and the other numerically. Therefore to find a beam marked B2, you just go down the alphabet side to B and then over the numeric side to 2. These are also referred to as "lines". Ex. Frame on Line 1 is usually an end frame. Walls are typically on lines A & B, and so on.

(Note that often times there may be more than one frame identical to others - Therefore these may not be individually marked, as they will be interchangeable.)

The drawing notes will also tell you which bays need wind bracing.

Also note that the number on the bottom right hand corner references your drawing AND job numbers. If ever you need to call your consultant this number should be kept handy for quicker service.

TYPICAL ANCHOR BOLT LAYOUT

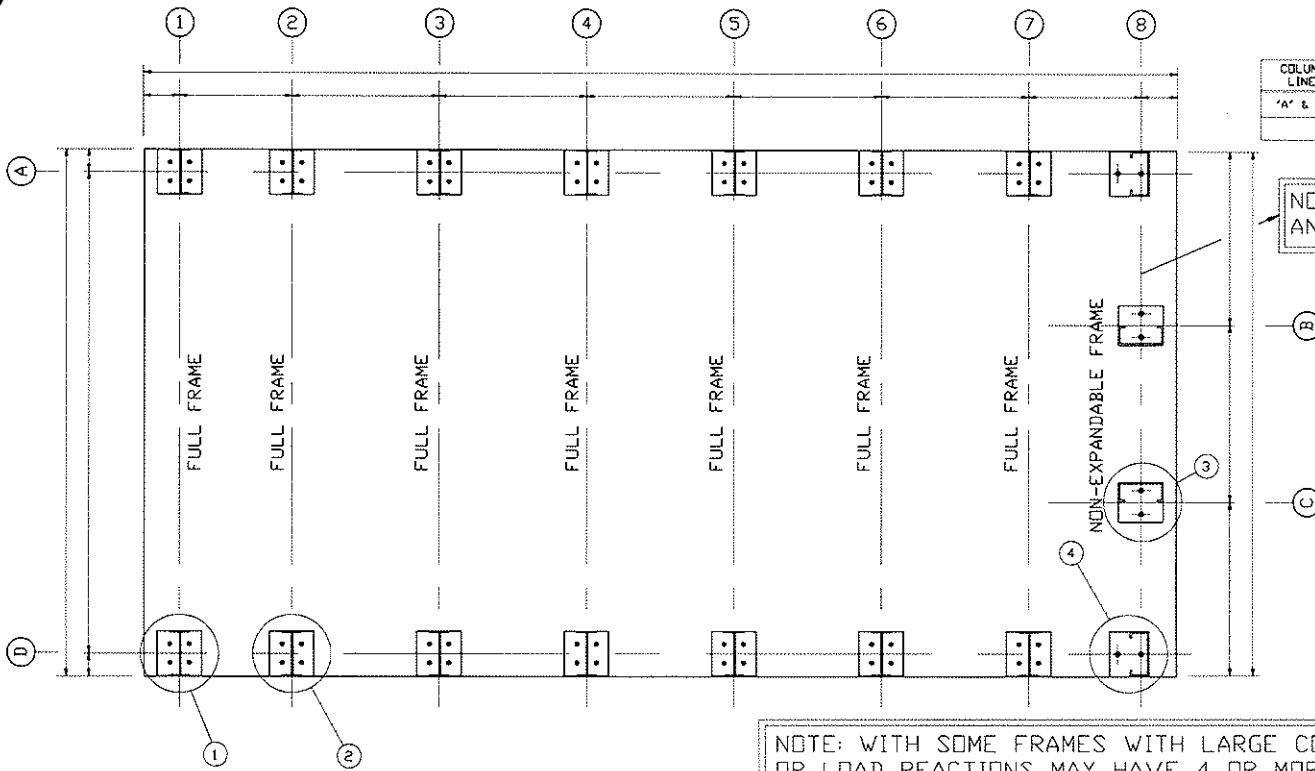

COLUMN REACTIONS (KIPS)						
COLUMN LINE		DEAD LOAD	LIVE LOAD	WIND/SEISMIC LOAD	BASE PLATE SIZE	ANCHOR BOLT QTY. & SIZE
		'A' & 'B'	VER.			±
	HOR.			±		

NOTE: NON-EXPANDABLE FRAME SHOWN IS AN AVAILABLE OPTION. (ONE OR BOTH ENDS)

NOTE: WINDBRACE RODS TO BE LOCATED IN BAYS BETWEEN COLUMN LINES ② & ③, ⑥ & ⑦.

GENERAL NOTES:

- THIS IS AN ANCHOR BOLT LAYOUT ONLY.
- THE OWNER IS RESPONSIBLE FOR THE FOUNDATION TO COMPLY WITH LOCAL BUILDING CODES.
- FOUNDATION DESIGN SHALL BE BASED ON THE COLUMN REACTIONS INDICATED AND THE SOIL BEARING CAPACITY.
- FOUNDATION AND EMBEDDED ITEMS (BY OTHERS) MUST BE LEVEL, SQUARE, AND ACCURATE TO ASSURE PROPER STEEL FRAME ASSEMBLY.
- ANCHOR BOLTS (BY OTHERS) TO BE # DIA. GRADE A307 UNLESS OTHERWISE NOTED AND SHALL HAVE PROPER EMBEDMENT AND COVER.
- DESIGN DATA: LIVE LOAD = # psf.
WIND SPEED/EXP. = ## mph/'#'
DEAD LOAD = ## psf. + steel

THIS BUILDING FRAME HAS BEEN DESIGNED IN ACCORDANCE WITH THE 1997 UNIFORM BUILDING CODE.

UNLESS OTHERWISE SPECIFICALLY NOTED, THE DIMENSIONS SHOWN HEREIN ARE FOR THE BUILDING FRAMES WITHOUT ANY INSULATION MATERIAL APPLIED TO THE OUTSIDE OF THE STRUCTURE. IF YOU ARE TO INSTALL ANY MATERIAL TO THE OUTSIDE, PLEASE MAKE SURE YOU ADD THE APPROPRIATE THICKNESS TO THE SLAB DIMENSIONS.

NOTE: WITH SOME FRAMES WITH LARGE COLUMNS AND OR LOAD REACTIONS MAY HAVE 4 OR MORE ANCHOR BOLTS.

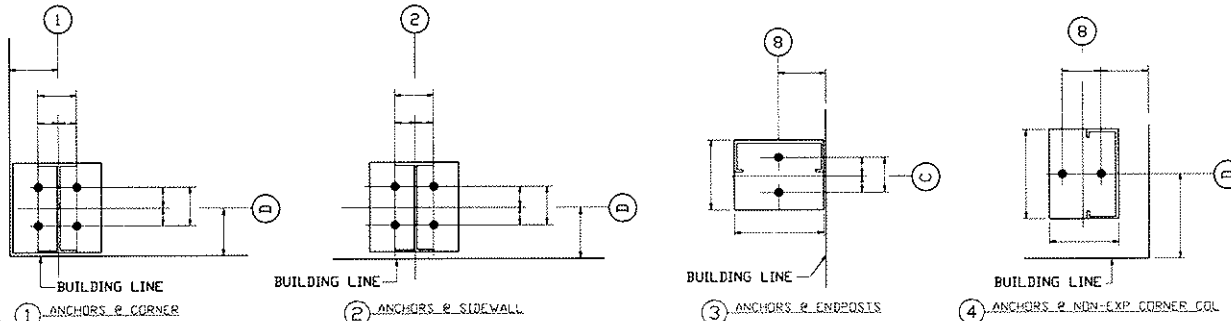

ANCHOR BOLT LAYOUT		
SCALE: NTS	APPROVED BY: ###	DRAWN BY: ###
DATE: 00/00/09		REVISED: ###

CAD DRAWING NUMBER		PROJECT NUMBER
####-AB.DWG		*****

TYPICAL ANCHOR BOLT LAYOUT

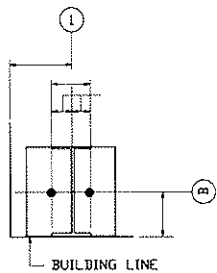
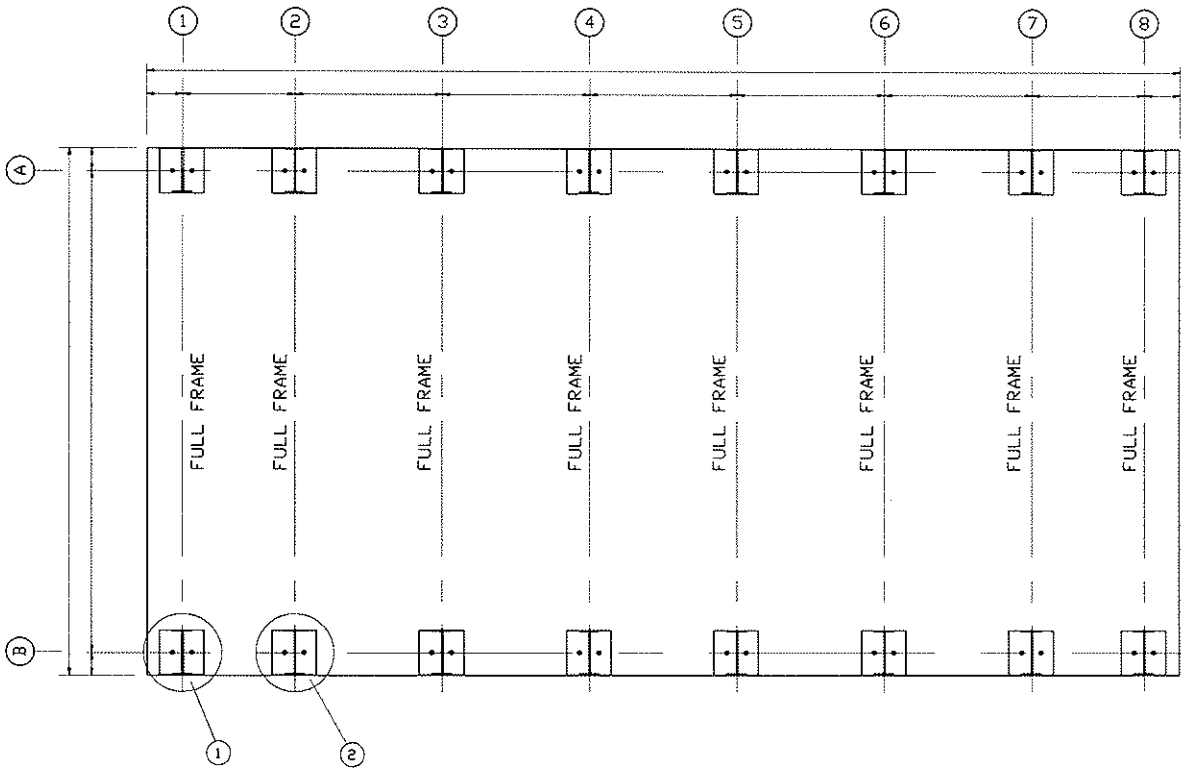

① ANCHORS_R_CORNER

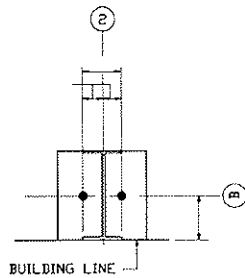

② ANCHORS_R_SIDEWALL

COLUMN REACTIONS (KIPS)						
COLUMN LINE		DEAD LOAD	LIVE LOAD	WIND/SEISMIC LOAD	BASE PLATE SIZE	ANCHOR BOLT QTY. & SIZE
'A' & 'B'	VER.			±		
	HOR.			±		

NOTE:
WINDBRACE RODS TO BE LOCATED IN BAYS BETWEEN COLUMN LINES ② & ③, ⑥ & ⑦.

GENERAL NOTES:

- 1) THIS IS AN ANCHOR BOLT LAYOUT ONLY.
- 2) THE OWNER IS RESPONSIBLE FOR THE FOUNDATION TO COMPLY WITH LOCAL BUILDING CODES.
- 3) FOUNDATION DESIGN SHALL BE BASED ON THE COLUMN REACTIONS INDICATED AND THE SOIL BEARING CAPACITY.
- 4) FOUNDATION AND EMBEDDED ITEMS (BY OTHERS) MUST BE LEVEL, SQUARE, AND ACCURATE TO ASSURE PROPER STEEL FRAME ASSEMBLY.
- 5) ANCHOR BOLTS (BY OTHERS) TO BE # DIA. GRADE A307 UNLESS OTHERWISE NOTED AND SHALL HAVE PROPER EMBEDMENT AND COVER.
- 6) DESIGN DATA: LIVE LOAD = # psf.
WIND SPEED/EXP. = 90 mph/'B'
DEAD LOAD = 4 psf. + steel

THIS BUILDING FRAME HAS BEEN DESIGNED IN ACCORDANCE WITH THE 1997 UNIFORM BUILDING CODE.

UNLESS OTHERWISE SPECIFICALLY NOTED, THE DIMENSIONS SHOWN HEREIN ARE FOR THE BUILDING FRAMES WITHOUT ANY INSULATION MATERIAL APPLIED TO THE OUTSIDE OF THE STRUCTURE. IF YOU ARE TO INSTALL ANY MATERIAL TO THE OUTSIDE, PLEASE MAKE SURE YOU ADD THE APPROPRIATE THICKNESS TO THE SLAB DIMENSIONS.

ANCHOR BOLT LAYOUT

SCALE: NTS APPROVED BY: DRAWN BY:

DATE: 08/08/09 REVISION:

CAD DRAWING NUMBER: PROJECT NUMBER:

###-AB.DWG *****

TYPICAL ERECTING PROCEDURES

1. Assembly rafter on the ground (if necessary, since the narrower frames may come in one section) and attach Bottom Chord Braces. (For M6000 you may want to put on one end of the Knee Brace). (For M8000 & 6000 you may want to bolt half of the Bottom Chord Spice Plate as well). **Note: on all single angle frames, the "open" face of all frames, should be facing in the same direction. The last frame will be in the opposite direction.**
2. Stand columns on both sides of a windbrace bay (usually between #2 & #3) and bolt down Anchor Bolts (finger tighten only).
3. Put windbrace rods into columns, drawing up the slack; do not tighten.
4. Set truss rafter on first interior frame columns and finger tighten bolts (at this point, you may want to cable brace your frame for safety).
5. Set second frame.
6. Set eave purlin and every 2ND Purlin putting only one fastener per end.
7. Using the windbrace rods, plumb the columns down the length of the building and using washers or shims under the base plates, align the columns across the width of the building. Now tighten nuts on Anchor bolts.
8. Continue to erect frames, using tie purlins and eave purlins to hold frames as work progresses. By using **tie purlins** only, you will save valuable time. When entire structure is up, release crane and then go back to complete installation of purlins, girts and fasteners, fully tightened.

As noted, these methods are popular methods used and will vary on each project's individual circumstances.



Following is a series of detailed illustrations showing how each of the individual components fit together.

We hope that this manual helps you with the enjoyment of your building, not only after it is up, but also during the time you experience the often overlooked satisfaction of completing a job well done.....

I-BEAM

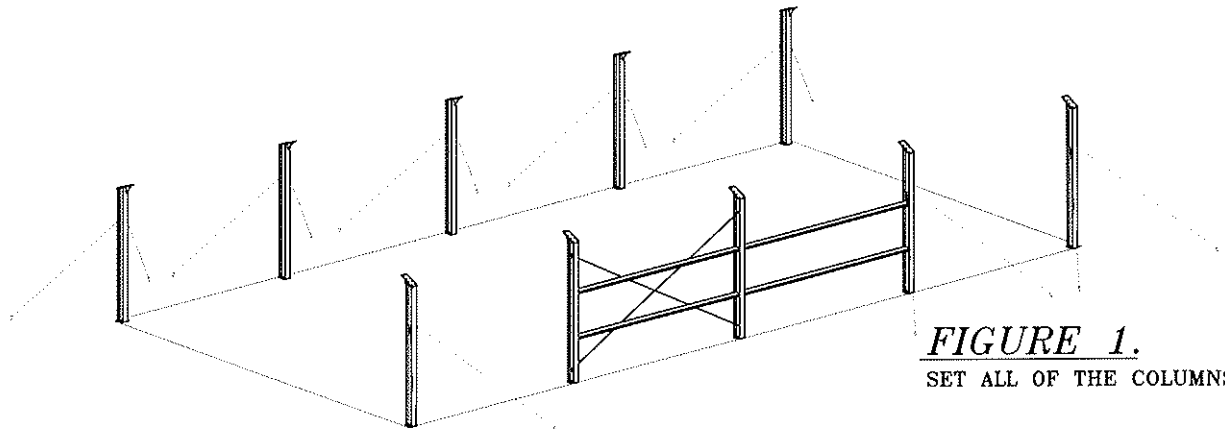

FIGURE 1.
SET ALL OF THE COLUMNS.

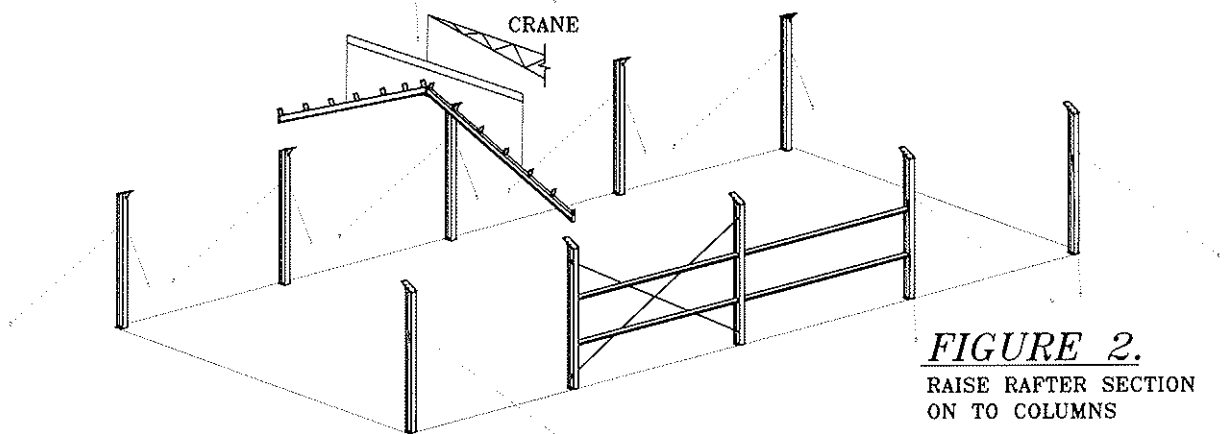

FIGURE 2.
RAISE RAFTER SECTION
ON TO COLUMNS

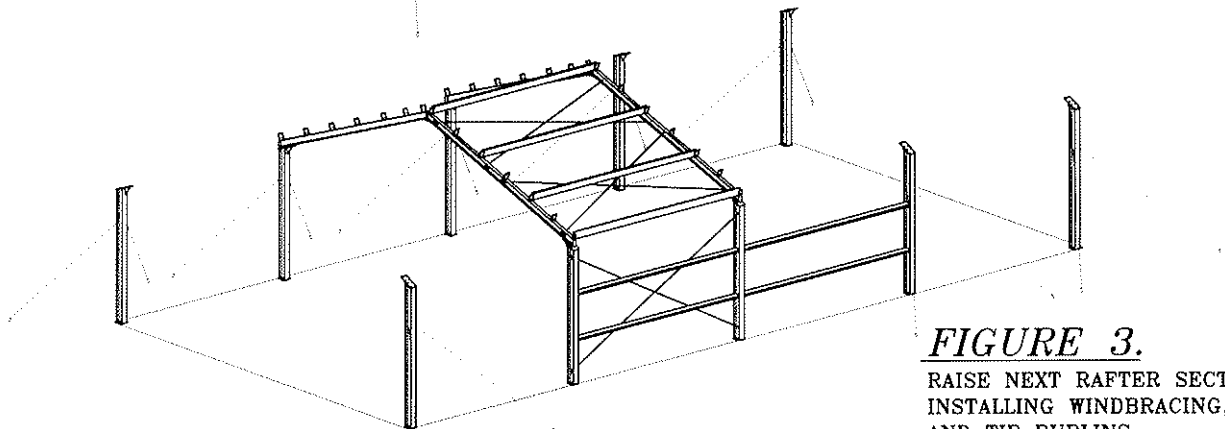

FIGURE 3.
RAISE NEXT RAFTER SECTION,
INSTALLING WINDBRACING,
GIRTS AND TIE PURLINS.

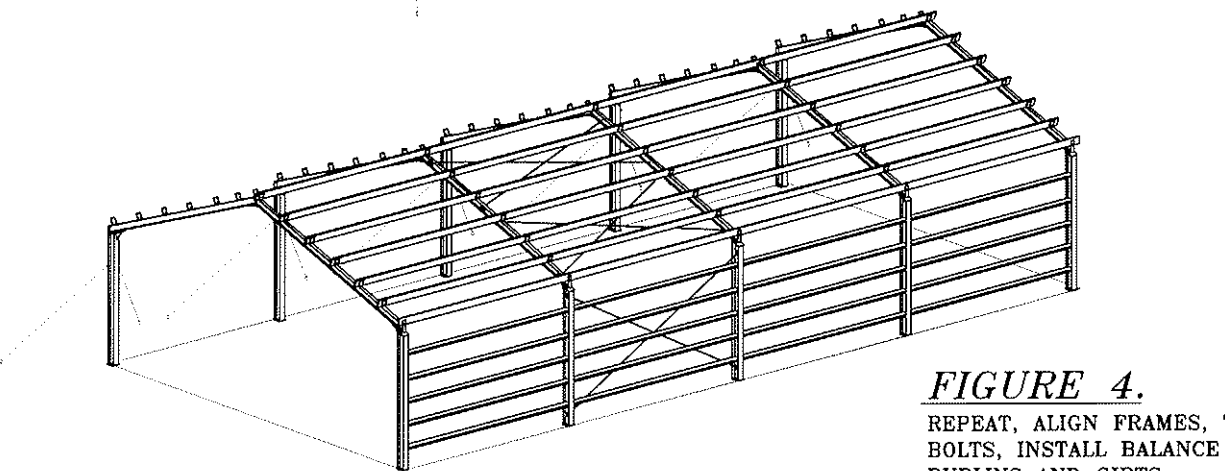
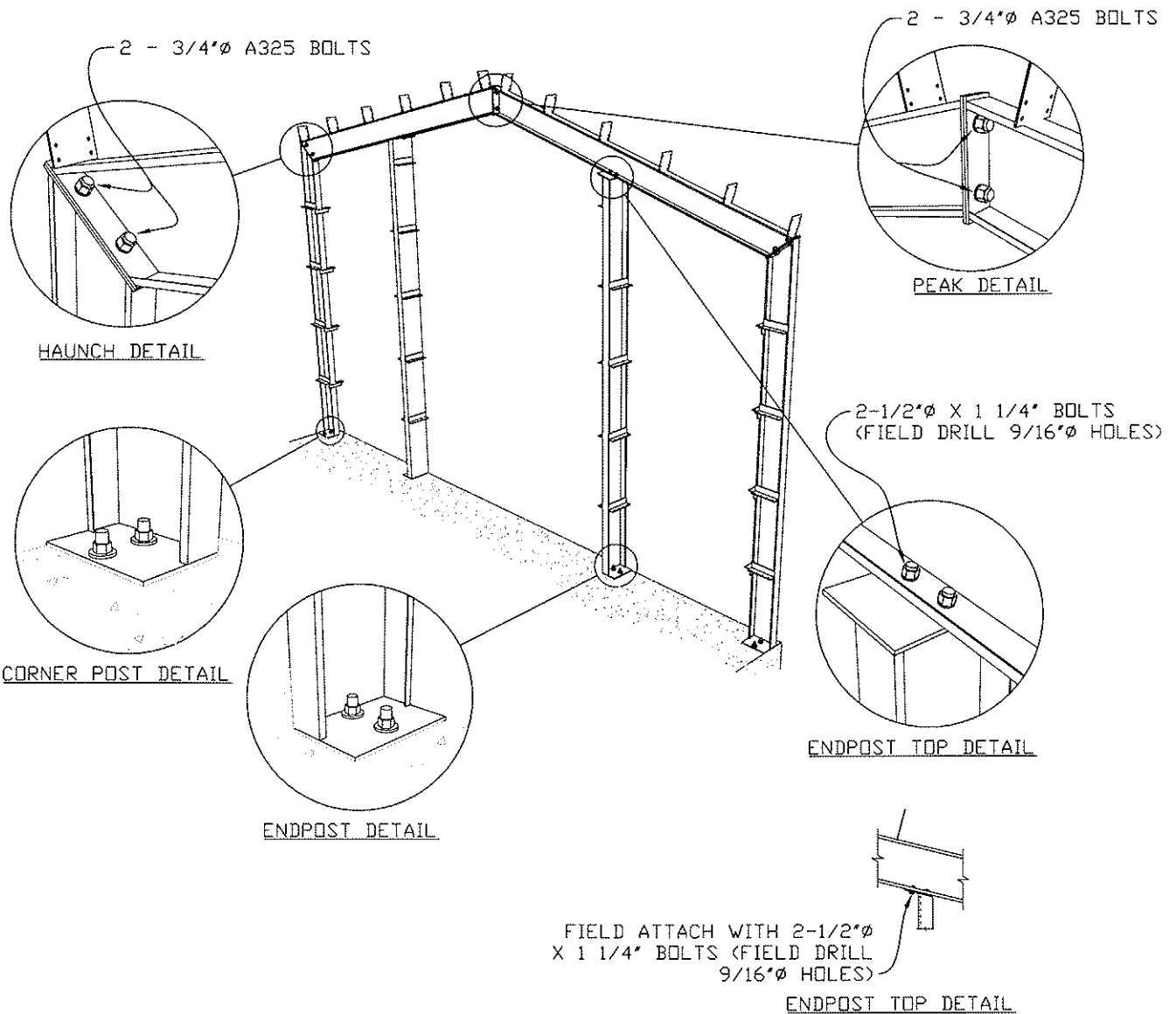

FIGURE 4.
REPEAT, ALIGN FRAMES, TIGHTEN
BOLTS, INSTALL BALANCE OF
PURLINS AND GIRTS.

NON-EXPANDABLE FRAME ILLUSTRATION (Typical)



Note: C 8x2.5x14Ga. Endpost & Rafters Shown (Typical)

- On a "Non-Expandable Frame" the endposts need to be "Bearing" that is they help to hold up the frame so as to meet the necessary loads. Therefore the connections on these are more fixed in nature and are as shown above. Furthermore these posts cannot be moved more than approximately one foot away from its intended position without having it checked by an engineer.

WIDE FLANGE COLUMN ANCHOR BOLT ATTACHMENT

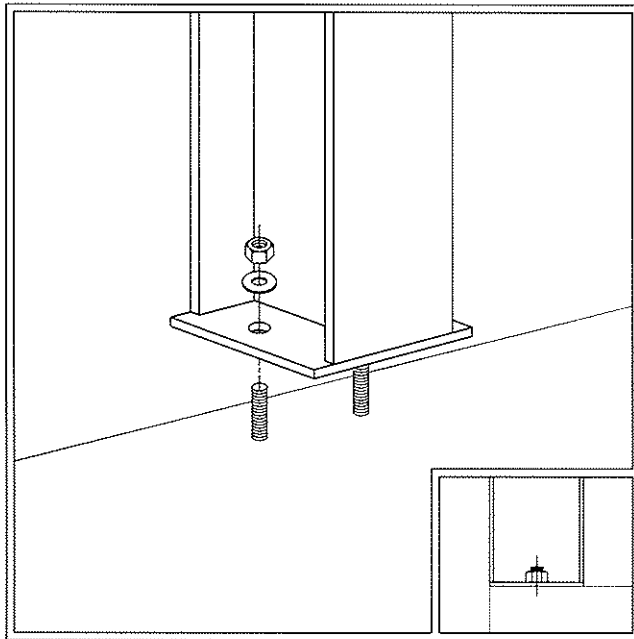

2 BOLT ANCHOR ATTACHMENT
(STANDARD)

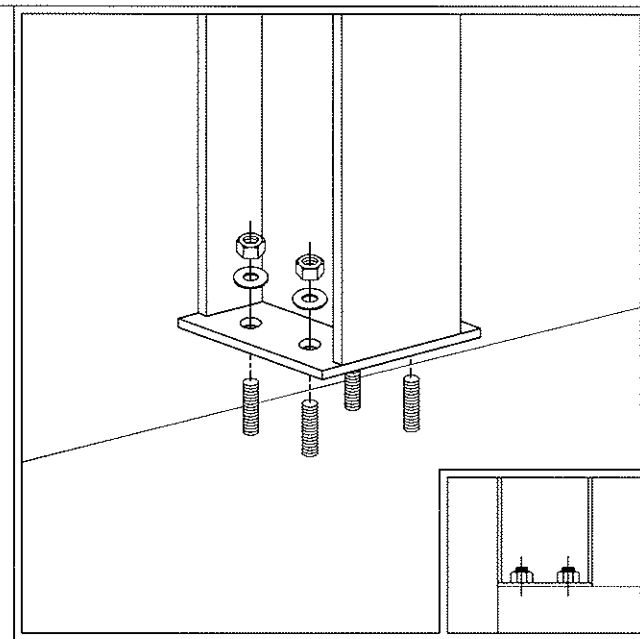

4 BOLT ANCHOR ATTACHMENT

Helpful Hints

- Do not tighten down bolts until frames have been aligned.
- It is not uncommon (pursuant to Engineer's approval) to put washers or shims to facilitate the frame leveling process.
- The anchor bolts themselves are usually supplied by customer or the foundation contractor. This is so because the bolts are usually needed before the delivery of the frames.
- When setting the anchors, make sure there is enough thread exposed to go through the base plate of the column, but not too exposed to interfere with the webbing.

HAUNCH OR EAVE CONNECTIONS

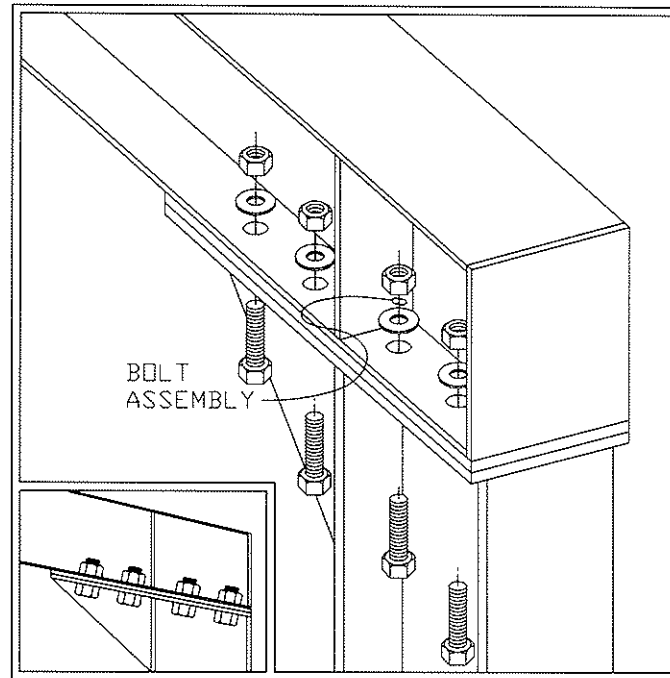

Helpful Hints

- The number of bolts in the haunch will vary with each frames individual design. (See your "Engineer Drawings" if you have requested them).
- Do not tighten down the bolts until frames have been aligned.
- Always insert bolts from under the haunch connection. (This better assures against nut loosening from gravity and vibrations).

TRUSS PEAK CONNECTION

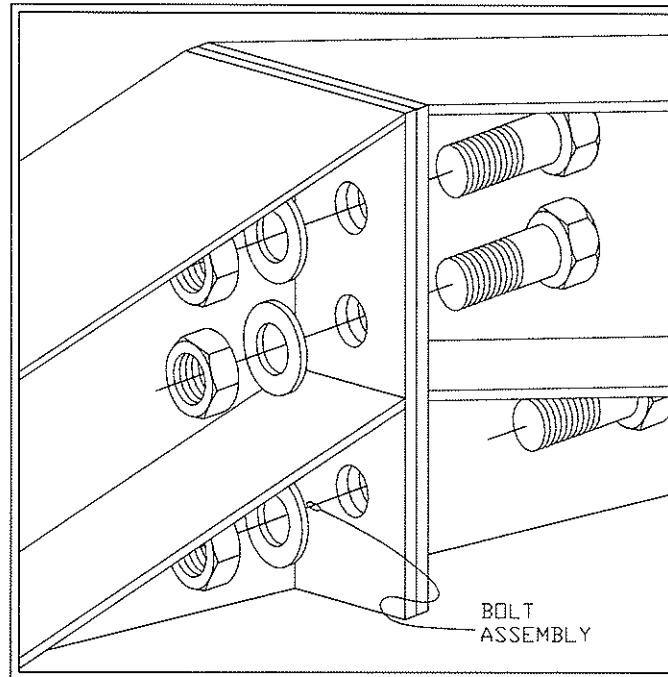

Helpful Hints

- The number of bolts and number of rows in the peak will vary with each frames individual design.
(See your "Engineer Drawings" if you have requested them).
- Do not tighten down the bolts until frames have been aligned.

WINDBRACE ROD ATTACHMENT

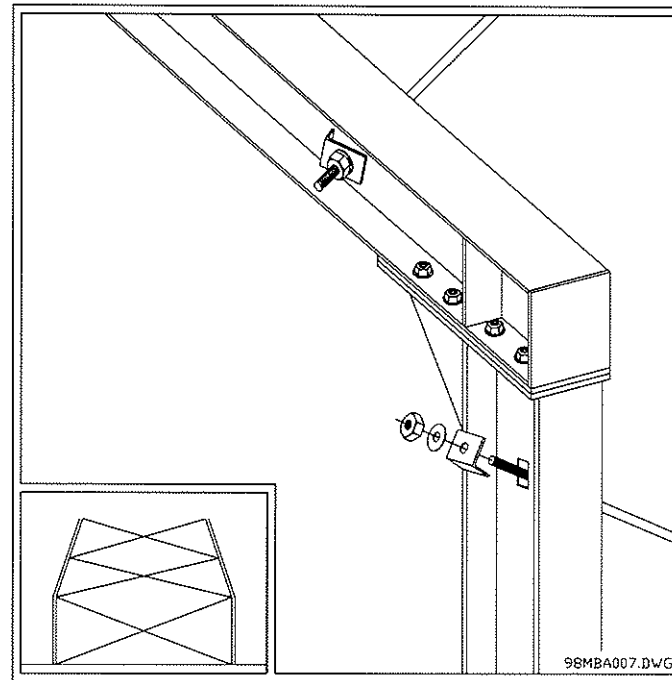

Helpful Hints

- Not all bays will have windbracing in them. (Even though each frame may have attachment plates or holes in column for them. This is done to facilitate the erection by making more pieces interchangeable.)
- * Refer to your anchor bolt layout to see which bays are braced.*
- One end of the windbrace rods has longer threading to facilitate the alignment of the frames. (it can go in either end)
- Note that the lengths for the rods can be found on your bill of lading. If something does not fit make sure you have the right rods since many times there are many different lengths of rods which go in different bays. Again these differences will be noted on the bill of lading.

ENDPOST DETAIL

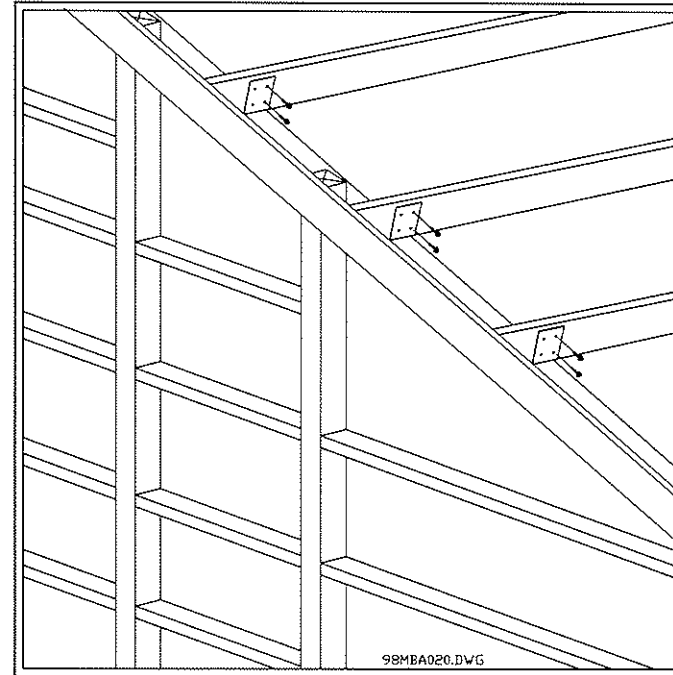
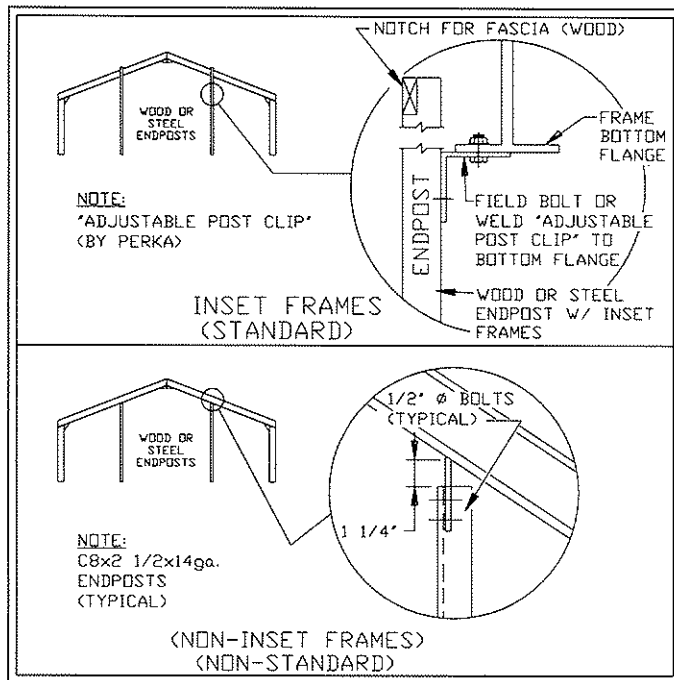

Helpful Hints

- A "Full Frame" (expandable) is self supporting and therefore does not need to have any endposts to support it. However, since it is often the case, that these frames are bought for the ends, in case of future expansion, posts will need to be fastened to them for the endwall framework, and this is shown in the top of the drawing above. If you requested it, a clip will be welded to the bottom chord of the frame to receive your end posts. (For Non - Inset / Non - Standard ends only)

- For buildings with wood endwalls and inset frames, attach post to bottom chord of frame with adjustable post clip (APC). This is "Standard" Application, so that the post can run past the truss, to allow for higher girts to attach sheeting to.

PURLIN ATTACHMENT

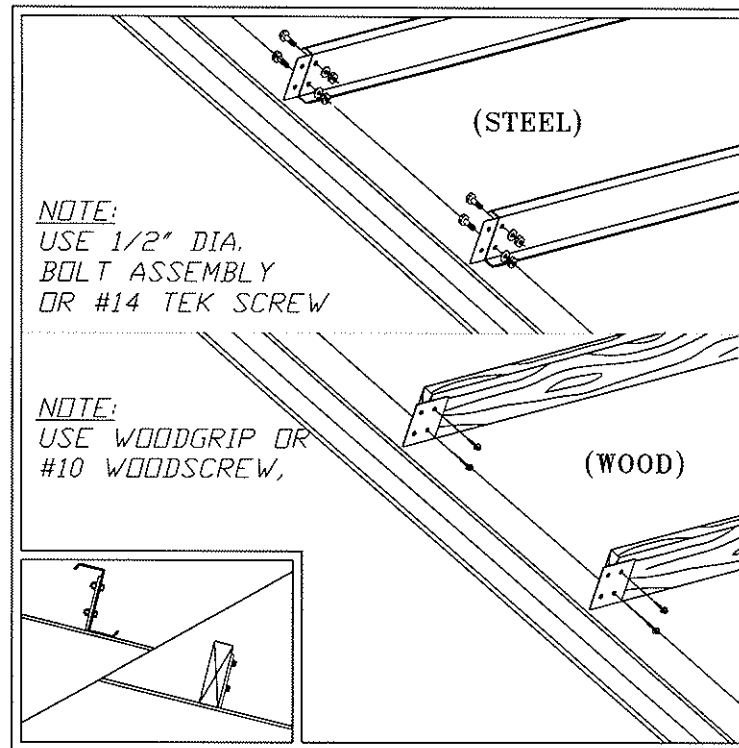

Helpful Hints

- When installing purlins before frames have been aligned, attach to clips with only one fastener per end to allow for movement when squaring your frames.
- Note that the purlins are installed to the top of the clip. except at the eave which should be installed on the bottom side and then bent up slightly (if required) to line up with the wall girt.
- With expensive equipment around, you may want to use tie purlins and eave purlins ONLY, to hold frames as work progresses. This could save you valuable crane time.

GIRT ATTACHMENT

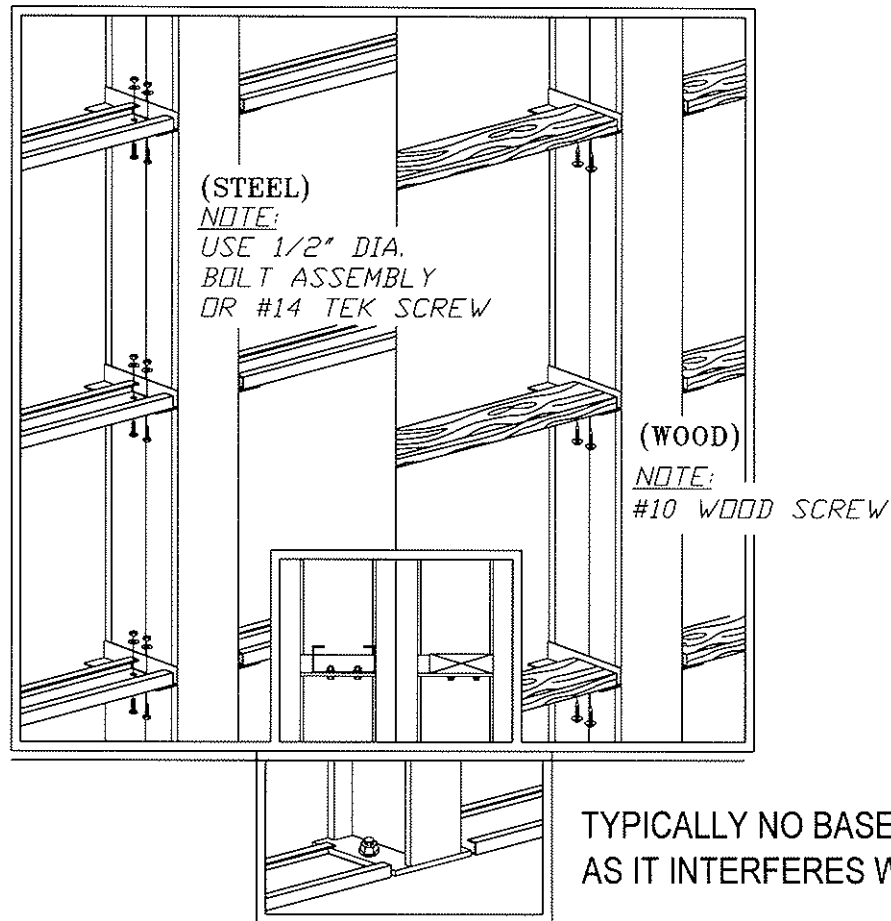

Helpful Hints

- When installing girts before frames have been aligned, attach to clips with only one fastener per end to allow for movement when squaring your frames.
- Note also that bolts should be installed in an upward fashion, again, to minimize the possibility of loosening from gravity and vibrations.

OVERHANG ATTACHMENT

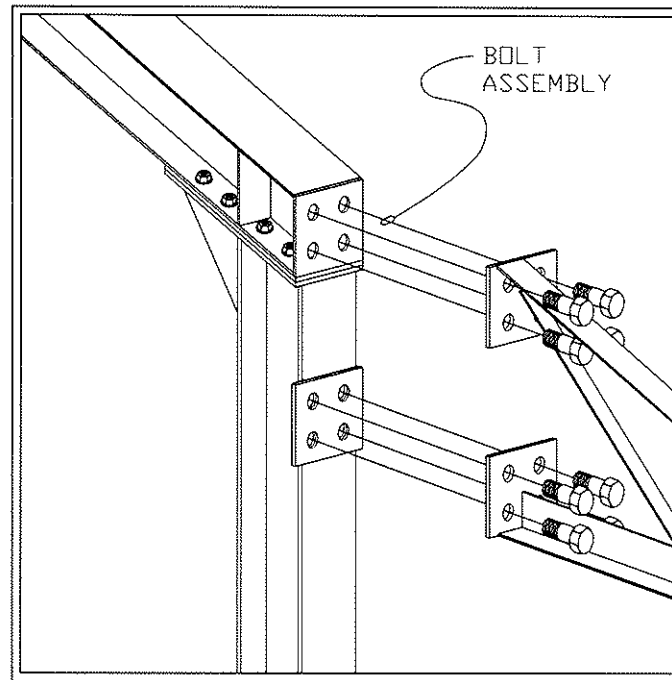

Helpful Hints

- The quantity of bolts in the overhang connection may vary with each frame's individual design. (See your "Engineering Drawings" if you have requested for them or your Bill Of Lading for notation on quantity provided).
 - After the main building frames have been set, squared, and tightened you may proceed with the attachment of the overhangs. By hand or with a crane (depending on the size of the overhang) lift into place the overhang frame, then start putting in the bolts, place all of the bolts with washers and nuts attached prior to tightening, then tighten all bolts.
- (If the above attachment is not square or in line, i.e. from foundation or frame settling, you can use spacer or shims to bring the overhang to proper levels. Any spacers or shims used should have holes to accommodate being placed over the bolts. (& not just between them.)

BASE TRIM

AT WOOD BASE

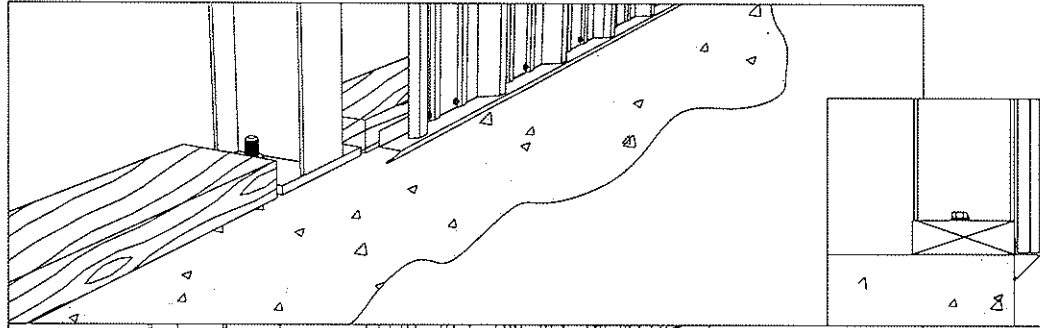

AT BASE ANGLE

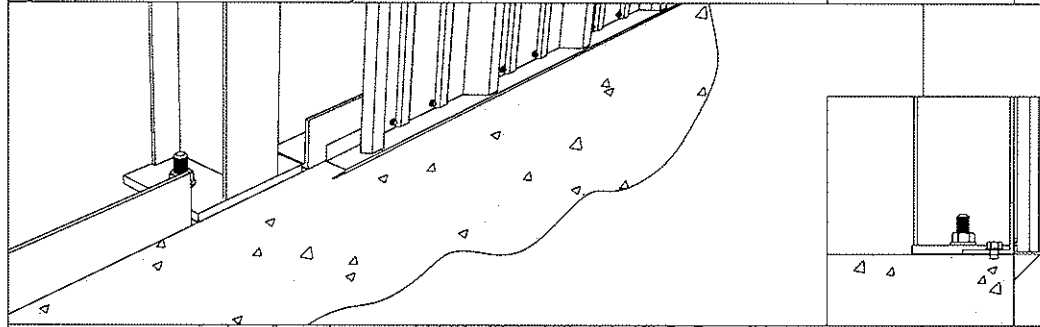

AT BASE CHANNEL

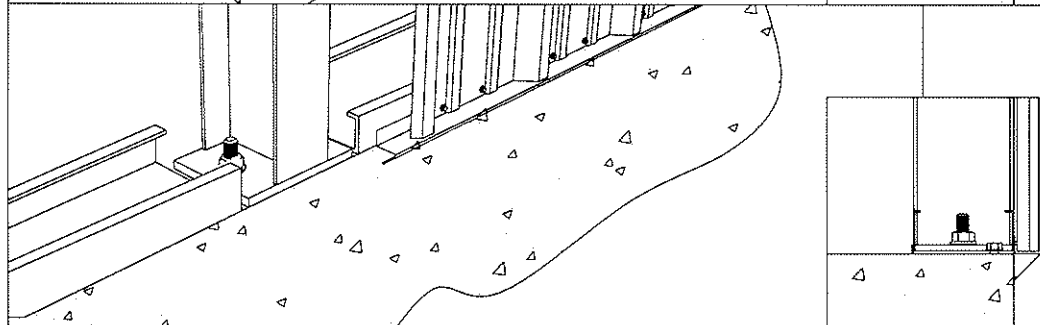

Helpful Hints

- Before installing any base trim, make sure the foundation wall is free of rough patches of concrete and that all voids and low spots are properly grouted.
- Start at one corner of the building and cut a 45 degree at one end for neat finish.
- At your discretion you can put down a bead of caulking underneath the base girt (preferably treated wood, unless all steel) to seal against any intrusions.

CORNER TRIM

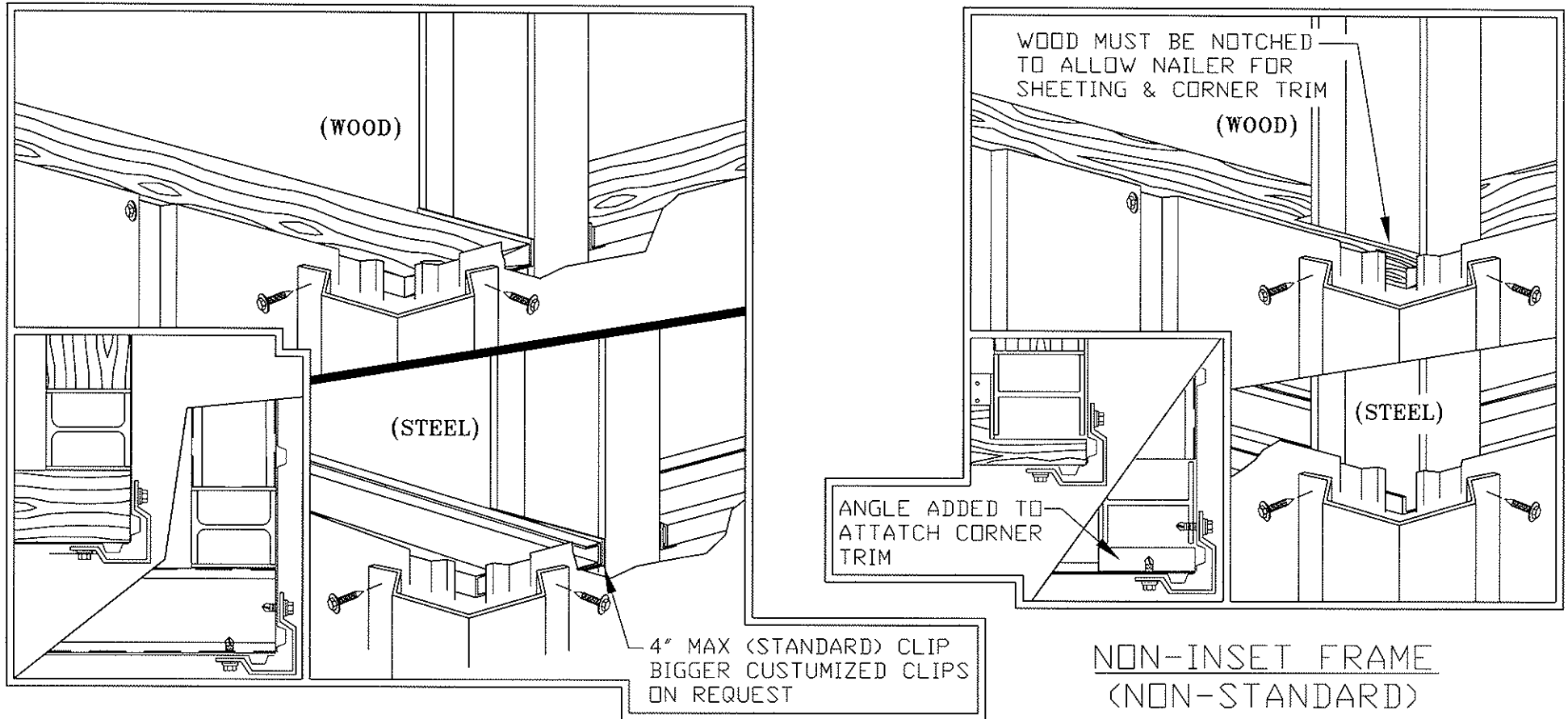

INSET FRAME
(STANDARD)

NON-INSET FRAME
(NON-STANDARD)

Helpful Hints

- When putting fasteners in, always try to penetrate into a girt so that a sturdy attachment is made for the sheeting as well as the trim itself.
- There are usually enough screws provided to put one on each side of the corner trim at every girt.
- The corner trim pieces are often identical to the gable trims, so do not be alarmed if you see more of this kind of trim than you would have expected.

EAVE FLASHING

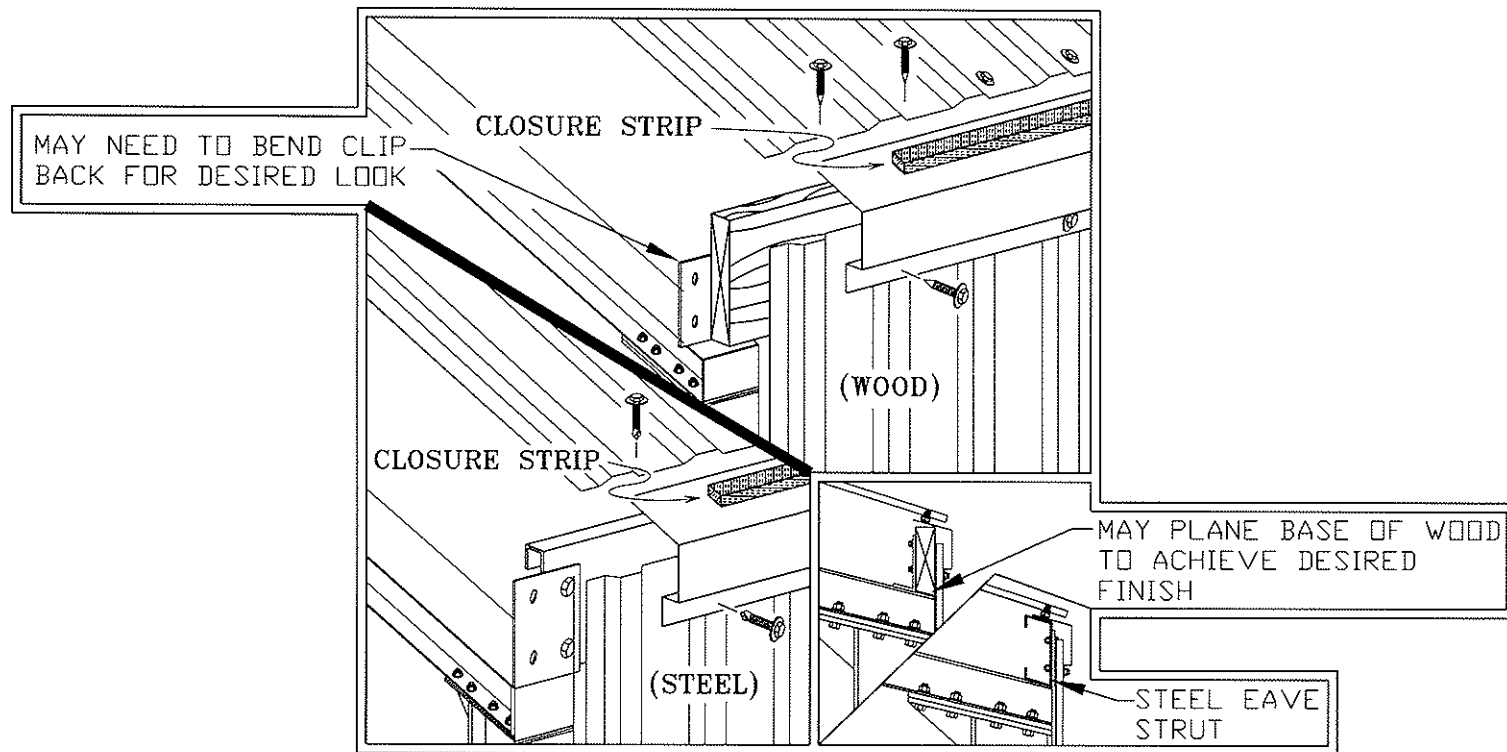

Helpful Hints

- When installing the roof sheathing, make sure the bottom screws are not put in since the eave trim is usually installed underneath.
- Note also that a closure strip is usually supplied to go in between the eave trim and the roof sheathing.
- Normally for the walls side of the trim, screws are put on at every second rib and extra care should be taken not to fasten too tightly so as not to crush the wall sheathing.
- For the top, screws are put on at each roof sheet rib, through the eave trim thereby fastening down both at the same time.

GABLE TRIM

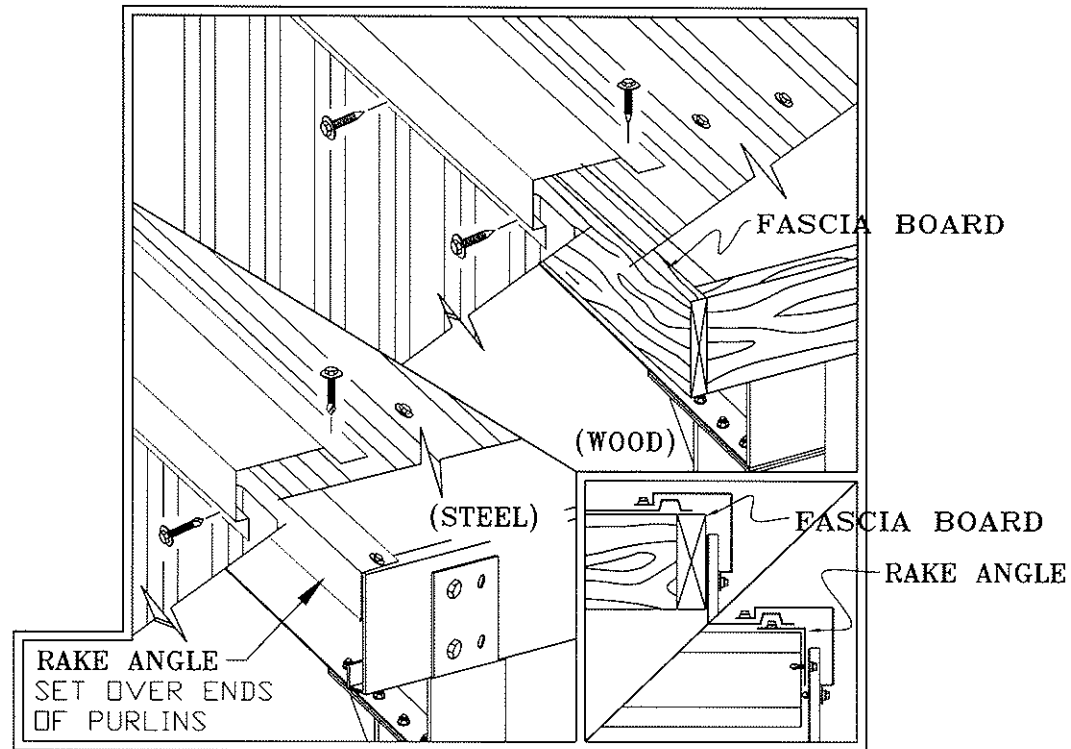

Helpful Hints

- The gable trims (which are often identical to the corner trims) are put on after the wall and roof sheets have been installed.
- Normally for the wall side of the gable trim, the screws are put at every second rib and extra care should be taken not to fasten too tightly so as not to crush the wall sheeting.
- For the top, screws are put on at each purlin for a sturdy connection. (No closure strips are needed here).

SHEETING DETAIL

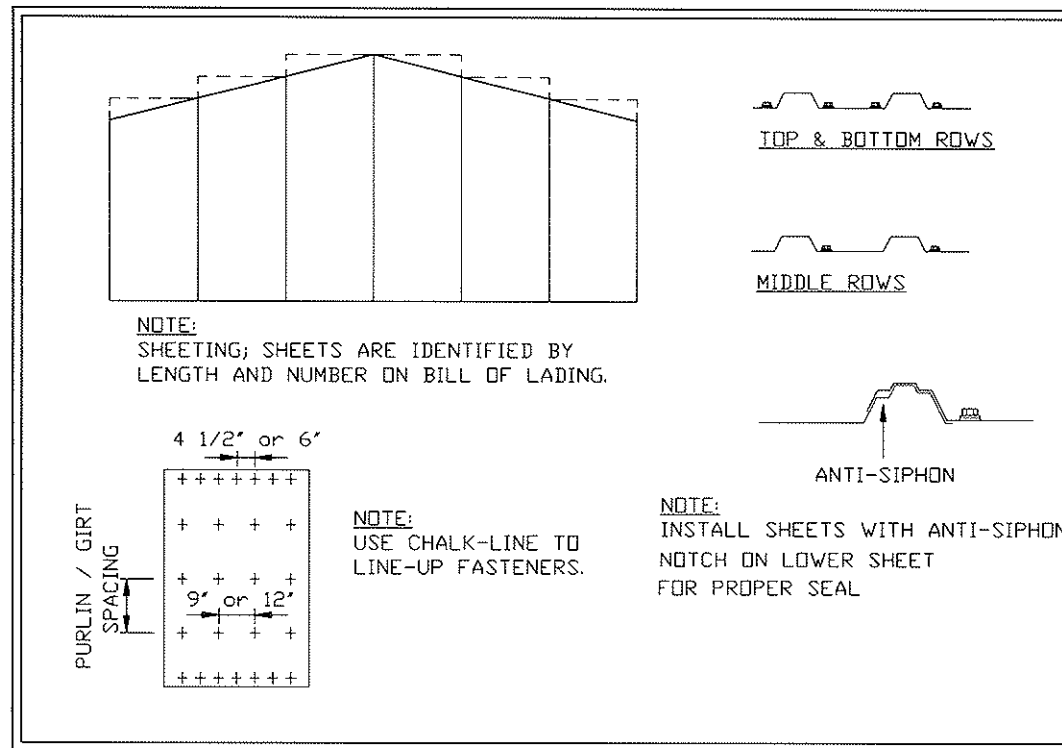

Helpful Hints

- When installing sheeting, it is recommended that you take extra time to make sure you do a "Quality Job" because this is what is going to show.
- Refer to your supplier bill of materials before you begin to use up your sheets. From these, you can understand how the sheeting takeoff was done and where the different pre-cut sheets are intended to go.
- As noted above, you do not need to put a screw in between every rib of your sheet. This needs only to be done at each end of each sheet, in between you only need one at every second rib. (Please refer to sheeting manufacturer's installation guide for best methods of application.)

PEAK TRIM

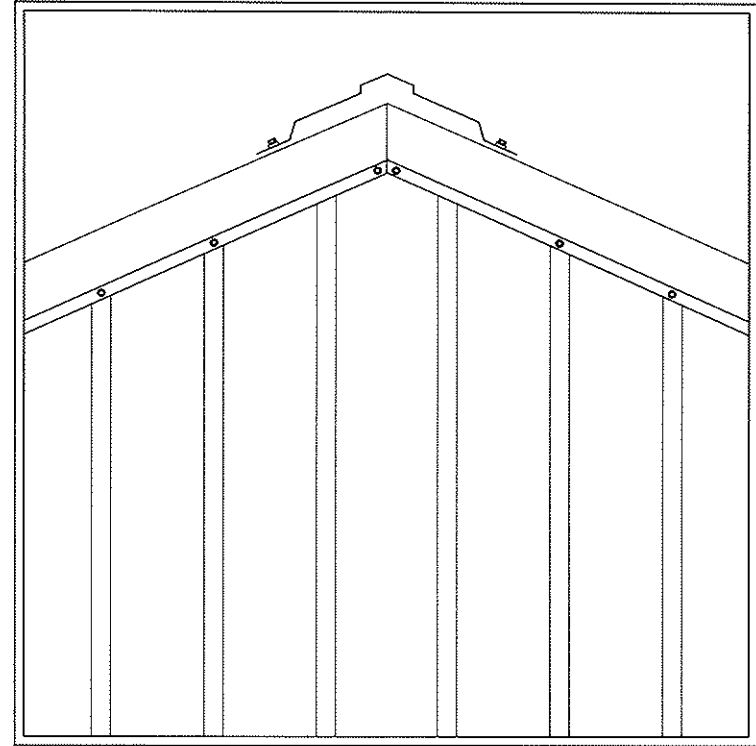
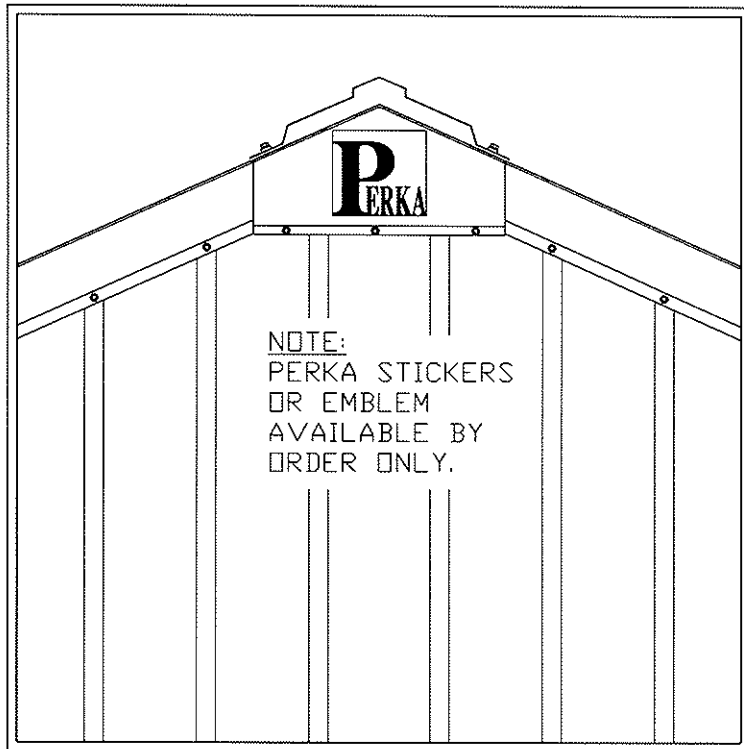

Helpful Hints

- The peak can be finished by merging the two gable trim pieces together with a diagonal cut on one of the pieces.
- Note that the gable trim goes underneath the ridge cap.
- After this you can install a Perka sticker or an emblem as you prefer.

RIDGE CAP DETAIL

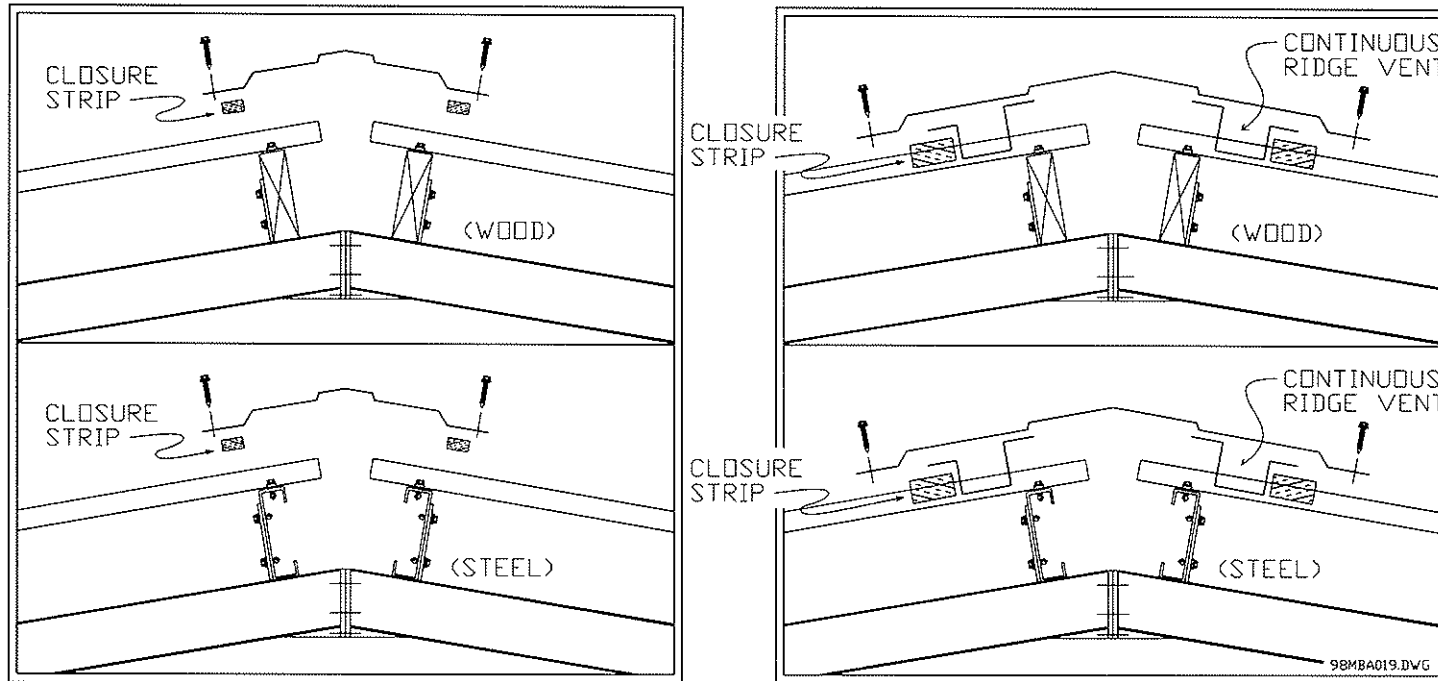

Helpful Hints

- Two rows of foam closures should be installed as illustrated.
- When installing your purlins make sure that the two runs of purlins at the ridge have been positioned on the top side of the ridge purlin clip. This allows for the strongest setting of the purlin on the top chord. Further it will be easier for you to fasten down your ridge cap into the purlins themselves.
- There are usually enough screws supplied to fasten down the ridge cap at each major rib (9" to 12") intervals on both sides.
- Do not screw into or through the foam closures. ****Refer to Vent Manufacturer for proper installation****

SHORT OVERHANG TRIM DETAIL

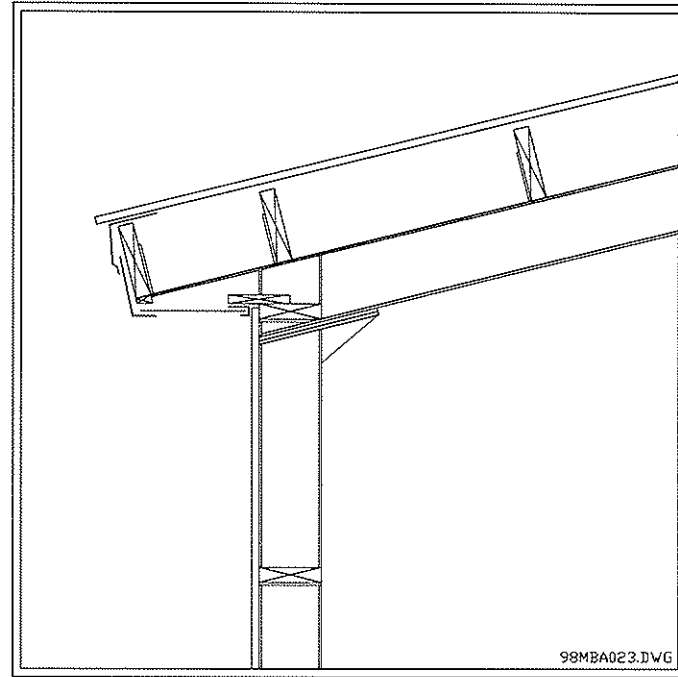
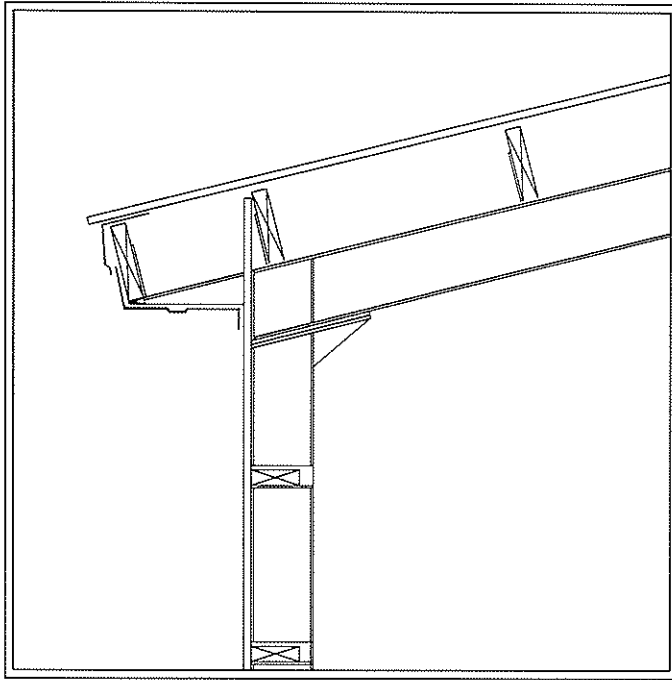

Helpful Hints

- Overhang finishing is simplified with the placement of a Girtr at the soffit level. (Which is standard)

LONG OVERHANG TRIM DETAIL

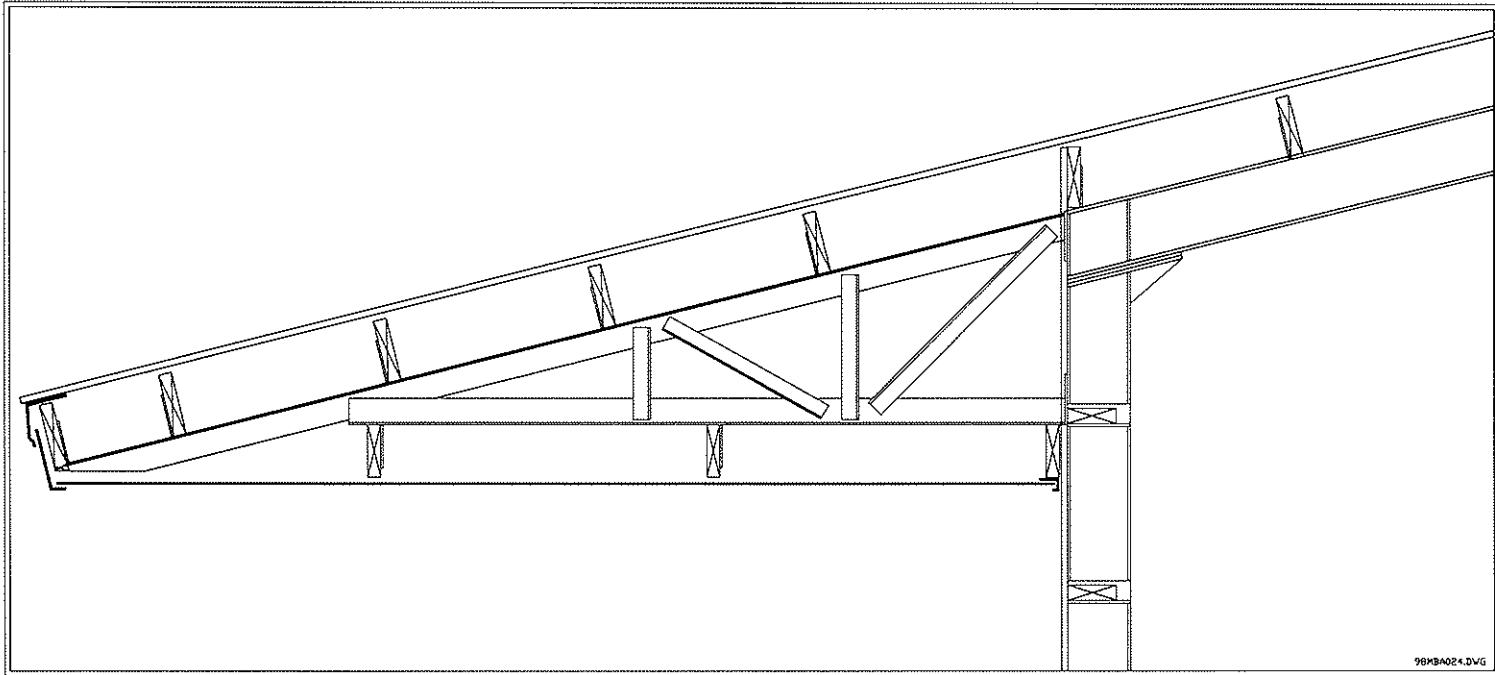

Helpful Hints

- Overhang finishing is simplified with the placement of a Girt at the soffit level. (Which is standard)

PERKA BUILDING FRAMES
THANKS YOU FOR YOUR BUISNESS

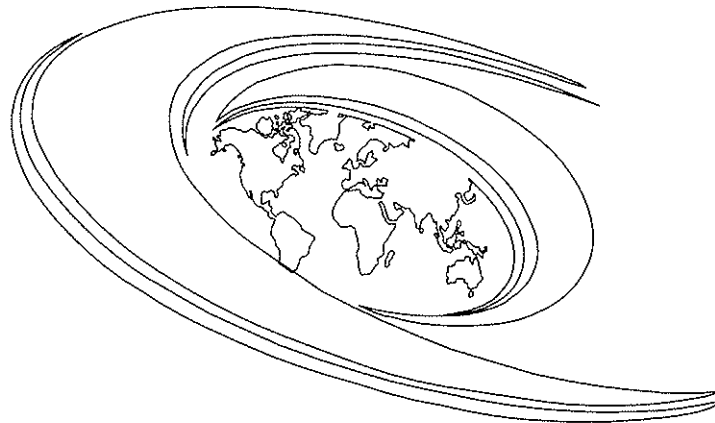

PERKA
WORLD CLASS BUILDINGS

SERVING THE UNITED STATES, CANADA, AND
OTHER COUNTRIES SINCE 1981

WEB: WWW.PERKA.COM

US EMAIL: PERKA@PERKA.COM